



Specification for

**Steel wedge gate valves
(flanged and
butt-welding ends) for
the petroleum,
petrochemical and
allied industries**

UDC 621.646.5:669.14:[622.313 + 662.753 + 665.6]

Co-operating organizations

The Petroleum Equipment Industry Standards Committee, under whose supervision this British Standard was prepared, consists of representatives from the following Government departments and scientific and industrial organizations:

British Gas Corporation
 British Mechanical Engineering Confederation
 British Rubber Manufacturers' Association Ltd.
 British Steel Industry*
 Council of British Manufacturers of Petroleum Equipment*
 Department of Energy (Oil)
 Oil Companies Materials Association*
 Process Plant Association

The organizations marked with an asterisk in the above list, together with the following, were directly represented on the committee entrusted with the preparation of this British Standard:

Association of Hydraulic Equipment Manufacturers
 British Chemical Engineering Contractors' Association
 British Industrial Measuring and Control Apparatus Manufacturers' Association
 British Plastics Federation
 British Ship Research Association
 British Valve Manufacturers' Association
 Engineering Equipment Users' Association
 Steel Castings Association

This British Standard, having been approved by the Petroleum Equipment Industry Standards Committee, was published under the authority of the Executive Board on 30 April 1975

© BSI 08-1999

First published January 1949
 First revision June 1954
 Second revision March 1960
 Third revision April 1975

The following BSI references relate to the work on this standard:
 Committee reference PSE/7 (formerly PEE/1)
 Draft for comment 71/37781 DC

ISBN 0 580 08991 6

Amendments issued since publication

Amd. No.	Date of issue	Comments
5837	June 1988	
6562	August 1990	Indicated by a sideline in the margin

Contents

	Page
Co-operating organizations	Inside front cover
Foreword	iii
<hr/>	
Section 1. General	
1 Scope	1
2 References	1
3 Nomenclature	1
4 Pressure classification	1
5 Pressure/temperature ratings	1
6 Nominal sizes	1
7 Information to be supplied by the purchaser	4
<hr/>	
Section 2. Design	
8 Body	4
9 Bonnet	7
10 Wedge	7
11 Yoke	8
12 Handwheel and handwheel nut	8
13 Stem and yoke sleeve	8
14 Stuffing box, packing and lantern ring	9
15 Bolting	9
16 Operation	9
17 Bypass	11
18 Soft seal rings	11
<hr/>	
Section 3. Materials	
19 Shell	11
20 Body seat rings	11
21 Bonnet gasket	11
22 Wedge	11
23 Yoke	11
24 Handwheel or chainwheel	11
25 Handwheel or chainwheel nut	11
26 Yoke sleeve	11
27 Yoke sleeve retaining nut	11
28 Gland	12
29 Trim	12
30 Lantern ring	12
31 Stem packing	12
32 Bolting	12
33 Plugs	12
34 Nameplate	12
35 Soft seals	12
36 Special applications	12
<hr/>	
Section 4. Marking	
37 Required markings	12
38 Body and nameplate markings	12
39 Body and bonnet markings	14
40 Nameplate markings	14
41 Additional markings	14
42 Omission of markings	14

	Page
Section 5. Testing	
43 Production pressure testing	14
Section 6. Shipping	
44 Preliminary	15
45 Preparation for despatch	15
46 Packaging	15
Appendix A Particular dimensions for each class of valve	16
Appendix B Application to piping systems with BS 4504 flanges	20
Figure 1 — Solid wedge gate valve, outside screw and yoke rising stem, cast or forged steel	2
Figure 2 — Butt-welding ends	5
Figure 3 — Location of tappings	6
Table 1 — Stuffing box bore and packing width	10
Table 2 — Trim materials, hardness and acceptable specifications	13
Table 2a — Test durations	14
Table 3 — Dimensions of Class 150 valves	16
Table 4 — Dimensions of Class 300 valves	17
Table 5 — Dimensions of Class 400 valves	17
Table 6 — Dimensions of Class 600 valves	18
Table 7 — Dimensions of Class 900 valves	18
Table 8 — Dimensions of Class 1 500 valves	19
Table 9 — Dimensions of Class 2 500 valves	19
Table 10 — Nominal pressure and class ratings and nominal size range	20
Publications referred to	Inside back cover

Foreword

This British Standard is one of a series for valves prepared under the authority of the Petroleum Industry Standards Committee. It was first published in 1949 when the materials referred to were described by reference to ASTM specifications. It is a metricated revision except that class designations and body to bonnet bolting sizes have not been converted into metric units. Imperial units are also given for some dimensions in order to comply with established international petroleum practice. The previous sections dealing with face-to-face and end-to-end dimensions, inspection and tests have now been omitted as these subjects have their own separate standards:

BS 2080 "*Face-to-face, centre-to-face, end-to-end and centre-to-end dimensions of flanged and butt-welding end steel valves for the petroleum, petrochemical and allied industries*".

BS 6755 "*Testing of valves*" Part 1 "*Specification for production pressure testing requirements*".

NOTE Requirements for final inspection and supplementary inspection at all stages of manufacture, previously specified in BS 5416-1:1974 (now withdrawn) should be stated by the purchaser in his enquiry or order.

The end flanges for valves of 600 mm (24 in) size and below are required to be in accordance with BS 1560 "*Steel pipe flanges and flanged fittings (nominal sizes $\frac{1}{2}$ in to 24 in) for the petroleum industry*" — Part 2 "*Metric dimensions*" (corresponding to ANSI B 16.5) and butt-welding ends are generally in accordance with ANSI B 16.25. For valves larger than 600 mm (24 in) size, end flanges are required to be in accordance with BS 3293 "*Carbon steel pipe flanges (over 24 in nominal size) for the petroleum industry*" or API Standard 605.

NOTE User requirements for valves generally in accordance with this standard but suitable for use in piping systems with flanges in accordance with BS 4504 "*Flanges and bolting for pipes, valves and fittings. Metric series*" are dealt with in Appendix B.

It is intended that valves complying with the requirements of this standard should be interchangeable as units with those of similar type specified in API 600. The present revision of BS 1414 is generally in accordance with the seventh edition of API 600 (November 1973) except that it has been extended to cover carbon steel valves in sizes up to 1 050 mm (42 in) in Class 150 and Class 300.

Acknowledgment is made to the American Petroleum Institute and to the American National Standards Institute for data used.

The titles of the American standards referred to in this standard and the foreword are as follows:

ANSI	
B 16.5	<i>Steel pipe flanges and flanged fittings (including supplements)</i>
B 16.25	<i>Buttwelding ends</i>
API	
Std 5b	<i>Specification for threading, gaging, and thread inspection of casing, tubing and line pipe threads</i>
Std 600	<i>Steel gate valves (flanged or butt-welding ends)</i>
Std 605	<i>Large-diameter carbon steel flanges</i>
ASTM	
A 182	<i>Forged or rolled alloy-steel pipe flanges, forged fittings and valves and parts for high temperature service</i>
A 276	<i>Stainless and heat resisting steel bars and shapes</i>
A 351	<i>Ferritic and austenitic steel castings for high temperature service</i>
B 124	<i>Copper and copper alloy forging rod, bar and shapes</i>
B 138	<i>Manganese bronze rod, bar and shapes</i>
B 148	<i>Aluminium bronze sand castings</i>
B 150	<i>Aluminium bronze rod, bar and shapes</i>
B 584	<i>Copper alloy sand castings for general applications</i>

A British Standard does not purport to include all the necessary provisions of a contract. Users of British Standards are responsible for their correct application.

Compliance with a British Standard does not of itself confer immunity from legal obligations.

Summary of pages

This document comprises a front cover, an inside front cover, pages i to iv, pages 1 to 20, an inside back cover and a back cover.

This standard has been updated (see copyright date) and may have had amendments incorporated. This will be indicated in the amendment table on the inside front cover.

Section 1. General

1 Scope

This British Standard specifies requirements for cast or forged carbon and alloy steel outside screw and yoke, solid wedge (plain or flexible) rising stem gate valves, with or without soft seals, with flanged or butt-welding ends, in nominal sizes within the range of 25 mm to 600 mm (1 in to 24 in) and Class 150 to Class 2 500. It also covers carbon steel valves in nominal sizes 650 mm to 1 050 mm (26 in to 42 in) in Class 150 and Class 300 only. This standard can also be used as a general guide where valves of material composition outside the scope of section three of this standard are required as, for example, for use in highly corrosive services or environments or for low temperatures (see clause 36).

2 References

The titles of the British Standards referred to in this standard are listed on the inside back cover.

3 Nomenclature

For the purposes of this British Standard the nomenclature for valve parts shall be as shown in Figure 1 which is also illustrative of some acceptable designs.

4 Pressure classification

This standard applies to valves of the following pressure class designations:

Class 150, Class 300, Class 400, Class 600, Class 900, Class 1 500 and Class 2 500.

The numerals in these class designations represent the primary service pressure ratings of the valves in pounds-force per square inch.

5 Pressure/temperature ratings

The pressure/temperature ratings applicable to valves specified in this standard shall be in accordance with Tables PE-1 to PE-12 of Appendix A of BS 1560-2:1970 for the particular shell material specified. There is, however, a temperature restriction on soft seals and on certain trim materials (see 18.3 and 29.5).

Where valves in accordance with this standard are to be used at service temperatures below $-30\text{ }^{\circ}\text{C}$, reference should be made to BS 3351. Service temperature refers to the temperature of the fluid in the line at the valve.

6 Nominal sizes

This standard covers valves of the following nominal sizes:

mm	(in)	mm	(in)	mm	(in)
25	(1)	150	(6)	500	(20)
32 ^a	(1¼) ^a	200	(8)	600	(24)
40	(1½)	250	(10)	650	(26)
50	(2)	300	(12)	700	(28)
65 ^a	(2½) ^a	350	(14)	750	(30)
80	(3)	400	(16)	900	(36)
100	(4)	450	(18)	1 050	(42)

^a These sizes have been retained only for the purpose of replacing existing valves. Their use for new construction in piping systems using BS 1560-2 end flanges should be avoided.

For each valve class the applicable sizes are shown in Appendix A.

Licensed Copy: Puan Ms. Norhayati, Petroliaam Nasional Berhad 4397000, 24 December 2003, Uncontrolled Copy, (c) BSI

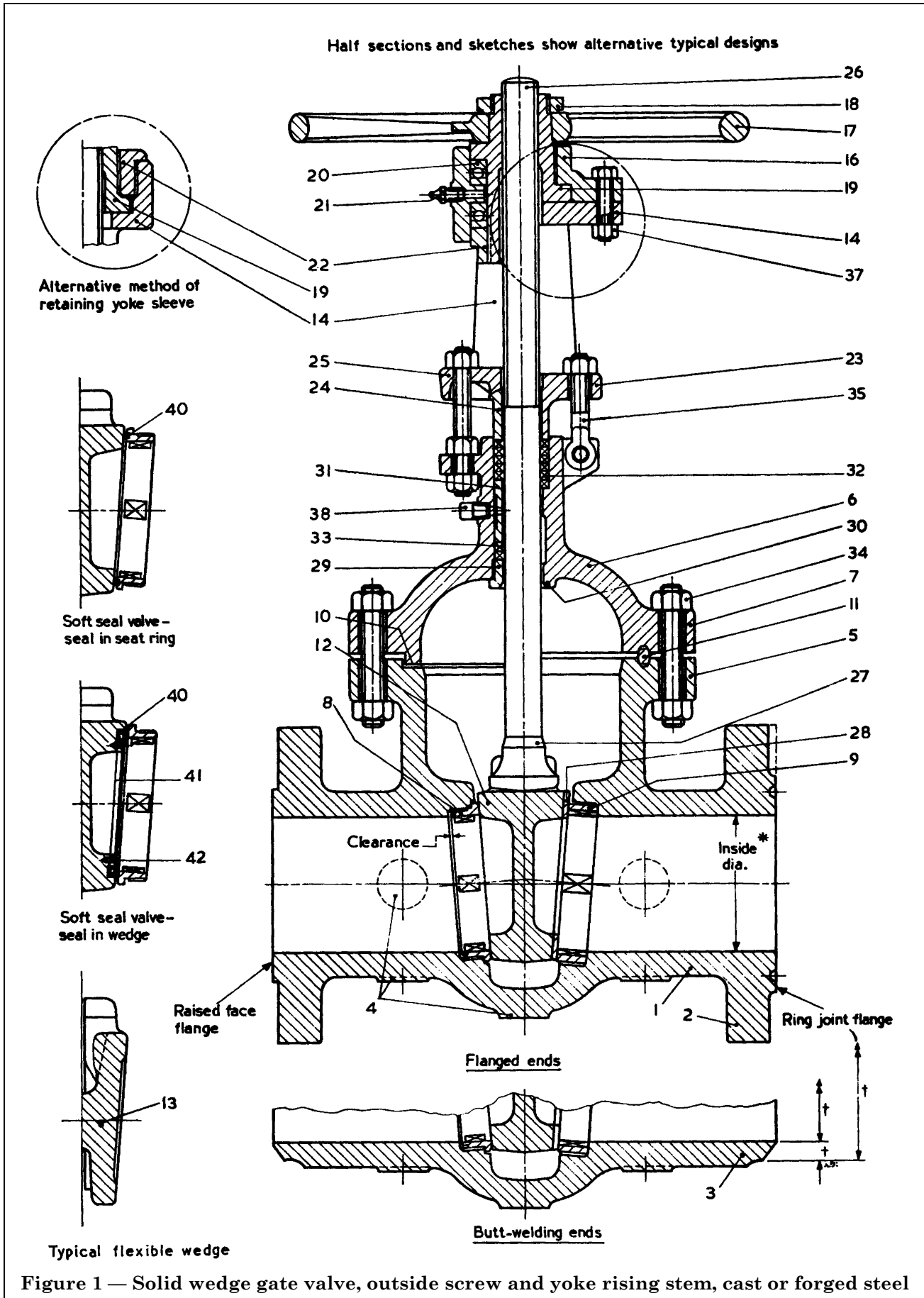
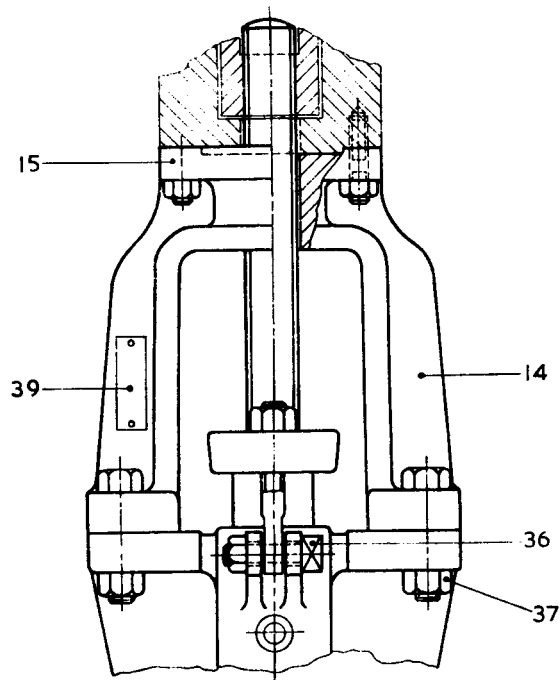

Figure 1 — Solid wedge gate valve, outside screw and yoke rising stem, cast or forged steel



View showing yoke with actuator mounting flange

Reference	Name of part	Material reference clause
1	Body	19
2	End flange	—
3	Butt-welding end	—
4	Body bosses	—
5	Body/bonnet flange	—
6	Bonnet	19
7	Bonnet flange	—
8	Shoulder seated ring	20 and 29
9	Bottom seated ring	20 and 29
10	Bonnet gasket	21
11	Ring joint	21
12	Plain wedge	22 and 29
13	Flexible wedge	22 and 29
14	Yoke	23
15	Actuator mounting flange	—
16	Yoke cap	—
17	Handwheel	24
18	Handwheel nut	25
19	Yoke sleeve	26
20	Yoke sleeve rolling bearing	—
21	Bearing lubricator fitting	—

Reference	Name of part	Material reference clause
22	Yoke sleeve retaining nut	27
23	One piece gland	28
24	Gland follower	28
25	Gland flange	28
26	Stem	29
27	Stem seat	—
28	Wedge facing ring	29
29	Back-seat bushing	29
30	Back seat	29
31	Lantern ring	30
32	Stem packing	31
33	Wiper rings	31
34	Bonnet stud-bolts and nuts	32
35	Gland bolt and nut	32
36	Gland lug bolt and nut	32
37	Yoke bolting	32
38	Stuffing box plug	33
39	Nameplate	34
40	Soft seal ring	35
41	Soft seal retaining ring	35
42	Soft seal retaining ring screws	35

NOTE These sketches are composite for the purpose of showing some typical variations in individual details and part names. A product utilising any combination of these details (except when such combination may be specifically prohibited in the text) or similar construction will be acceptable provided it complies with this standard in all other respects.

* See Appendix A.

† See Figure 2.

Figure 1 — Solid wedge gate valve, outside screw and yoke rising stem, cast or forged steel

7 Information to be supplied by the purchaser

Certain clauses of this standard permit alternatives and the purchaser may require features which depart from the requirements of this standard. The purchaser should state in the enquiry and order the following (the items marked with an asterisk are mandatory).

- a) *Class and nominal size (see clauses 4 and 6 and B.7).
- b) *If soft seals are required and, if so, whether these are required to be in the wedge seats or body seats (see clauses 5 and 18).
- c) *Whether flanged or butt-welding ends are required.
 - 1) If flanged ends are required, whether welded-on flanges are acceptable (see 8.5); the type of facing (see 8.6); for sizes above 600 mm (24 in), whether flanges are to be in accordance with BS 3293 or API Std 605.
 - 2) If butt-welding ends are required, the pipe schedule number or wall thickness and outside diameter [see 8.8 b)].
- d) If allowance is to be made for the passage of a pipe scraper [see 8.8 c)].
- e) If shell tappings are required and, if so, the location and the type of thread if other than API Std 5B (see 8.9 and 9.8).
- f) If a particular form of wedge is required (see 10.2).
- g) If the yoke is to be fitted with a flange for actuator or gearbox mounting (see clause 11).
- h) Details of type of operation required if other than direct-handwheel operated (see clauses 12 and 16).
- i) If a lantern ring is to be provided for Class 300 to Class 2 500 valves (see 14.4).
- j) If a bypass is required, give the full specification of the bypass valve, piping and connections (see clause 17).
- k) *The shell material (see clause 19).
 - l) If a special bonnet gasket is required (see clause 21).
- m) *The nominal trim material symbol (see 29.2).
- n) If any special stem packing is required, or specify packing design temperature if above 400 °C (see clause 31).

o) Material(s) for bonnet, gland, and yoke bolting if required for operation at process design temperatures below – 30 °C or above 480 °C, or for other special operating conditions (see clause 32).

p) Material requirements for valves in highly corrosive services or environment, or for low temperature service (see clause 36).

q) Test and inspection requirements in accordance with BS 5146.

r) Requirements for tropical or special packaging (see clause 46).

Section 2. Design

8 Body

8.1 For the body the design criteria specified in 8.2 to 8.11 shall be observed.

8.2 The body shall be designed to minimize pressure loss as well as corrosive and erosive effects. The body end ports shall be circular.

8.3 The wall thickness of the body shall conform to the shell thickness given in Appendix A. Drilling of, or pinning to, the wall of a pressure-containing part, e.g. for nameplate fixing, is not permissible where it would reduce the effective thickness below the minimum permitted value.

8.4 Face-to-face dimensions for raised face flanged end valves and end-to-end dimensions for butt-welding end and ring joint flanged end valves shall conform to the dimensions specified in BS 2080.

8.5 End flanges shall be cast or forged integral with the body except that flanges may be attached by welding if so specified in the order. The welds of end flanges attached by butt-welding shall comply with the requirements of BS 3351 and shall have any necessary heat treatment as required by BS 3351 to ensure that they are suitable for service temperatures down to – 30 °C. Flange attachment by other welding processes shall be the subject of agreement between the manufacturer and the purchaser.

8.6 End flanges shall comply with the requirements of BS 1560-2 for valves up to and including 600 mm (24 in) nominal size and BS 3293 or API Std 605 (as specified by the purchaser) for valves over 600 mm (24 in) nominal size. End flange facings shall be one of the types shown in Figures 1 and 2 of BS 2080. The purchaser shall specify the type of facing required.

Valves generally in accordance with this standard but suitable for use in piping systems with BS 4504 flanges shall comply with the requirements of Appendix B.

8.7 Butt-welding ends shall comply with the details shown in Figure 2.

NOTE When welding butt-welding end valves into piping systems the welds and any necessary heat treatment shall comply with the requirements of BS 3351.

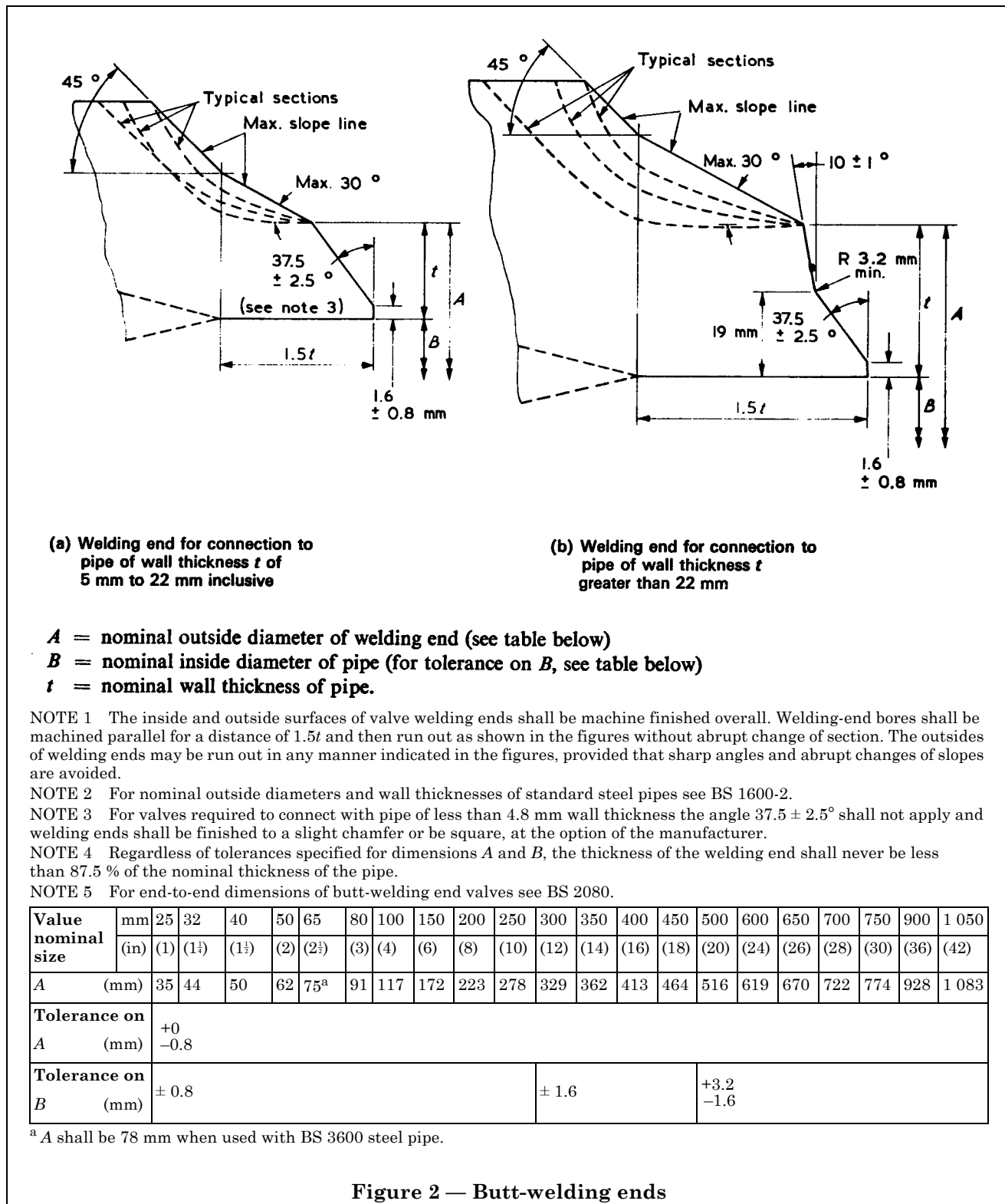

Figure 2 — Butt-welding ends

8.8 For flanged valves the minimum inside diameter of the body end port shall be as specified in Appendix A.

For butt-welding end valves the minimum inside diameter of the body end port shall comply with the details given in Figure 2. Pipe schedule number or pipe wall thickness and outside diameter of the pipe shall be specified by the purchaser.

If it is required to pass a pipe scraper through the valve, this shall be specified by the purchaser.

8.9 Valves of nominal sizes 80 mm (3 in) and above shall have provision for tappings at the seven positions A to G shown in Figure 3. When the metal thickness of the body is insufficient to provide the effective length of the thread for body tapping, or the body presents an uneven surface, bosses shall be provided.

Provision should be made for the body tappings as follows:

Nominal size	Pipe tapping size	Minimum diameter of boss
mm	in	mm
50 to 100	$\frac{1}{2}$	38
150 and 200	$\frac{3}{4}$	44
250 and 300	1	54
350 and larger	$1\frac{1}{2}$	70

Holes shall not be drilled or tapped unless specified in the order, which should then state the thread required (if other than API Std 5B) and the location (see Figure 3). Tapped holes shall be provided with plugs.

On valves of nominal sizes below 80 mm (3 in), provision for tapping shall be as specified by the purchaser and shall comply with Figure 3 as regards location.

Where a bypass is to be provided see clause 17.

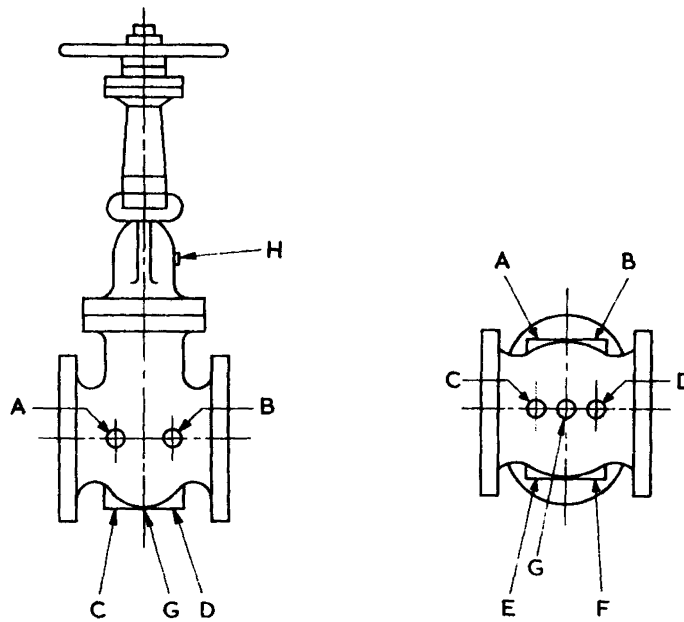

Third angle projection.

NOTE For valves below 80 mm the bonnet tapping may be positioned to suit the manufacturer.

Figure 3 — Location of tappings

8.10 Separate seat rings in the body shall be employed except as indicated in a) and b) of this subclause.

- a) Austenitic steel valves, in which case these may have integral seats.
- b) Austenitic or hard-facing (body) seat materials which may be deposited directly on the valve body and the minimum finished thickness of the deposit shall then be 1.6 mm. Direct deposition of 13 % chromium seat material on to the body is not permissible.

Separate seat rings may have directly deposited seating material in accordance with any of the specifications indicated in Table 2, in which case the minimum thickness of the deposit shall be 1.6 mm.

Seat rings may be shoulder-seated or bottom-seated at the option of the manufacturer and may be screwed in, rolled in or welded in unless one particular method is specified by the purchaser. Threaded seat rings shall be provided with lugs or slots to facilitate removal. Shoulder-seated rings shall be designed so that any clearance between the back of the ring and the bottom of the ring recess shall be not greater than 1.6 mm for sizes 300 mm (12 in) and smaller, and 3.2 mm for sizes 350 mm (14 in) and larger (see Figure 1). Tack welding may be employed to prevent loosening (see BS 3351). The faces of the rings shall be smooth finished with the sharp corners at the inner and outer edges removed to prevent scoring of the wedge faces.

The use of a sealing medium on the threads is not permissible.

The use of soft seals in body seats is dealt with in clause 18.

8.11 Wedge guides shall be provided in the bodies of all valves to cover for the full travel of the wedge so that the seating surfaces of the wedge do not touch the body seats until near the point of closure. These guides shall be of the male or female type, so placed as to engage with the guide slots or lugs of the wedge. Valve guides shall be integral with the body except that for valves of nominal sizes 650 mm (26 in) and larger the guides may be separate components welded into position.

9 Bonnet

9.1 For bonnets the design criteria specified in 9.2 to 9.8 shall be observed.

9.2 Wall thickness of the bonnet shall conform with shell thickness as shown in Appendix A. Drilling of, or pinning to, the wall of a pressure containing part, e.g. for nameplate fixing, is not permissible where it would reduce the effective thickness below the minimum permitted value.

9.3 The body to bonnet connection shall be flanged and the flange facings shall be male-and-female, tongue-and-groove, or ring joint type, except for Class 150 which may be a plain (flat) face.

Where possible, body/bonnet flange facings and gaskets shall be of standard dimensions in accordance with BS 1560-2, BS 3293 or API Std 605.

9.4 Bonnet flanges and body/bonnet flanges shall be of circular form in all cases, except that:

- a) for Class 150 valves they may be oval;
- b) for all valves below nominal size 80 mm (3 in) they may be square or rectangular.

Flanges shall be spot-faced or back-faced as specified in BS 1560-2.

9.5 The body to bonnet joint shall have at least four stud-bolts of the following minimum size except that for nominal sizes below 50 mm (2 in) studs may be used (see also 15.2).

Nominal size	Minimum nominal bolt size
mm	in
25 to 50	$\frac{3}{8}$
80 to 200	$\frac{1}{2}$
250 and larger	$\frac{5}{8}$

9.6 To permit repacking of a valve in the open position while in service, a machined conical or spherical back seat shall be provided in the bonnet to contact a corresponding seating surface on the valve stem. Bonnet back seats shall be in a bushing, except that for a valve with either an austenitic or hard faced trim the seating surface may be a welded deposit. On an austenitic steel valve the back seat may be on either an integral surface or welded-on hardfacing. Welded deposits shall have a minimum finished thickness of 1.6 mm.

9.7 The hole at the back seat shall be designed to provide adequate guidance for the stem and to prevent packing extrusion.

9.8 Valves of nominal size 80 mm (3 in) and larger shall have provision for a $\frac{1}{2}$ in tapping at the location H shown in Figure 3. Provision for a $\frac{1}{2}$ in tapping shall also be made on valves smaller than nominal size 80 mm (3 in) at a position convenient to the manufacturer. The thread shall be stated if other than API Std 5B.

10 Wedge

10.1 For wedges the design criteria specified in 10.2 to 10.5 shall be observed.

10.2 A solid wedge, which may be fabricated by welding, shall be provided. It may be either a plain wedge, having essentially a trapezoidal (or an I) cross section, or a flexible wedge having a tapered H or inverted U cross section. It shall be free from pockets which could form liquid traps when the valve is mounted with the stem vertical. Unless the order specifies a plain wedge or a flexible wedge, either may be supplied.

10.3 Wedges may have integral faces or may have separate facing rings rolled in, welded on or directly deposited. Directly deposited facings shall have a minimum finished thickness of 1.6 mm.

The use of soft seals in wedge seats is dealt with in clause 18.

10.4 Guide slots or lugs to engage the body guides shall be provided on the wedges of all valves. The slots or lugs shall be of ample length and shall extend below the horizontal centre line of the wedge. Wedges shall be provided with a suitable slot at the top to receive the button or tee-head of the stem.

10.5 The design shall provide adequate seating width, both before and after wear of the seating surfaces. The minimum values of wear travel shall be as follows:

Nominal size		Minimum wear travel
mm		mm
25 to	50	2
65 to	150	3
200 to	300	6
350 to	450	10
500 to	600	13
650 to	1 050	15

11 Yoke

The yoke may be integral with the bonnet or, if separate, self-locating on the bonnet and attached by suitable bolting. The yoke shall be machined where it comes in contact with the bonnet and the yoke sleeve. When specified in the order the yoke shall be provided with an actuator or gearbox mounting flange (see 16.4). The yoke and the actuator or gearbox mounting shall be of adequate strength to support the actuator or gearbox at any angle of installation of the valve.

12 Handwheel and handwheel nut

12.1 The handwheel shall be of the spoke-and-rim design, preferably with not more than six spokes. In the smaller sizes, where the space between the spokes is limited, the provision of knobs or studs projecting beyond the outside diameter of the handwheel is desirable.

12.2 The valve shall be opened by turning the handwheel in an anti-clockwise direction. The handwheel shall be suitably marked with an arrow and the word OPEN to indicate the direction of rotation to open the valve.

12.3 The handwheel shall be retained on the yoke sleeve by a threaded handwheel nut.

13 Stem and yoke sleeve

13.1 The minimum stem diameter shall be as given in Appendix A.

13.2 The stem shall be of one piece design and shall have a bevelled or spherical seat machined on it to seat on the bonnet back seat when the valve is fully opened.

13.3 The projection outside the yoke sleeve of the stem threads on a new closed valve shall be as follows unless a closer tolerance is required by the purchaser:

Nominal size		Limits of stem projection
mm	(in)	mm
25 to 50	(1 to 2)	2 to 10
65 to 150	(2½ to 6)	3 to 15
200 to 300	(8 to 12)	6 to 20
350 to 450	(14 to 18)	10 to 30
500 to 600	(20 to 24)	13 to 40
650 to 1 050	(26 to 42)	15 to 50

13.4 The stem shall have threads of Acme or other trapezoidal form and shall have an integral end of button or tee-head form, fitting into a slot in the top of the wedge, to provide flexibility between the stem and the wedge. The design shall prevent turning of the stem or disengagement of the stem from the wedge during service. Threaded or pinned connections between the stem and the wedge shall not be used.

13.5 The yoke sleeve shall be internally threaded to suit the stem and shall be designed to permit ready removal of the handwheel without allowing any axial movement of the stem.

13.6 All surfaces of the yoke sleeve in contact with the yoke shall be machined. Rolling bearings shall be fitted to the following nominal sizes of valve:

Class 400	250 mm (10 in) and larger.
Class 600 and upwards	150 mm (6 in) and larger.

Adequate provision for lubrication shall be made in all classes and nominal sizes.

14 Stuffing box, packing and lantern ring

14.1 The stuffing box bore shall conform to the dimensions given in Table 1 and shall have a minimum depth, based on square section packing of the nominal width shown in the table, as follows.

Class 150	equivalent to six rings of packing.
Class 300 and above	equivalent to a lantern ring length and seven rings of packing.

14.2 Packing glands shall be of one piece, one piece bushed, or two piece self-aligning design. Vertically split glands shall not be used. The gland proper of a two piece gland shall have a shoulder on its outer end to prevent complete entry of the gland into the stuffing box.

14.3 The packing width shall be as specified in Table 1. The packing may be of square, rectangular or chevron section.

14.4 Class 150 valves shall not have lantern rings. Class 300 to Class 2 500 valves shall be supplied with a lantern ring when specified in the order. Lantern rings shall have two holes, spaced at 180°, provided at each end for removal. These holes shall either be through-holes for hooks or tapped 5-40 UNC. When a lantern ring is provided it shall be positioned such that with square section packing there will be five rings of packing above the lantern ring and two below. The stuffing box shall then be tapped opposite the centre of the installed lantern ring and fitted with a round head pipe plug in accordance with BS 3799 of not less than $\frac{1}{4}$ nominal size. A boss shall be provided if necessary to ensure minimum thread engagement.

15 Bolting

15.1 This clause is concerned only with that bolting which forms part of the valve and is not concerned with bolting for flanged connections between the valve and a pipeline or pipe fitting.

15.2 The allowable working stress in bolting material for bonnet flanges at the primary service pressures given in clause 4 shall not exceed 62 MPa assuming that the pressure acts upon an area circumscribed by the outside periphery of the gasket or, for a ring joint, that the pressure acts through the pitch circle of the ring joint.

Bonnet flange bolting shall be by stud-bolts with a nut at each end of the stud-bolt except that for valve sizes below 50 mm (2 in) studs in accordance with BS 2693-1 may be used. Stud-bolts and nuts shall comply with the requirements of BS 4882:1973, sections 1 and 3.

15.3 Gland bolting may be of one of the following types.

- Hinged bolt secured by either a headed bolt passed through the eye and secured by a nut or a pin passed through the eye and effectively secured. Cotter pins are not acceptable as the sole securing devices.
- Stud-bolt passed through a plain hole in the flange on the bonnet neck and secured to the flange by two nuts.
- Stud-bolt screwed into a tapped hole in the flange on the bonnet neck and secured by a lock nut.
- Headed bolt passed through a plain hole in the flange on the bonnet neck.

Headed bolts in slotted brackets on the bonnet neck shall not be used. Bolts, stud-bolts and nuts shall be threaded metric or UNC and dimensioned in accordance with BS 4882, BS 1768 (below $\frac{1}{2}$ in nominal size), BS 1769, BS 3692 or BS 4190 except that square head, side head and tee head bolts are acceptable. Studs are not permissible.

15.4 Yoke bolting shall be threaded metric or UNC and dimensioned in accordance with BS 4882, BS 1769, BS 3692 or BS 4190. Studs are not permissible.

16 Operation

16.1 Valves shall be direct-handwheel operated unless otherwise specified in the order.

16.2 If chainwheel operation is required, the type of chainwheel shall be specified in the order which shall also specify any chain to be supplied.

16.3 If gear operation is required, the type of gearing and its arrangement and the design maximum differential pressure across the valve shall be specified in the order.

16.4 If actuator operation is required, the details of the actuator and its power supply together with the design maximum pressure differential across the valve shall be specified in the order.

For multi-turn actuators the attachment dimensions shall be as specified in BS "Flange attachment dimensions of actuators to general purpose valves" (in course of preparation).

Table 1 — Stuffing box bore and packing width^a

1	2	3	4	5	6
Nominal stem diameter		Nominal packing width		Nominal bore of stuffing box	
mm	(in)	mm	(in)	mm	(in)
15.9	$(\frac{5}{8})$	6.4	$(\frac{1}{4})$	29.4	$(1 \frac{5}{32})$
17.5	$(\frac{11}{16})$	6.4	$(\frac{1}{4})$	31.0	$(1 \frac{7}{32})$
19.0	$(\frac{3}{4})$	6.4	$(\frac{1}{4})$	32.5	$(1 \frac{9}{32})$
22.2	$(\frac{7}{8})$	6.4	$(\frac{1}{4})$	35.7	$(1 \frac{13}{32})$
25.4	(1)	6.4	$(\frac{1}{4})$	38.9	$(1 \frac{17}{32})$
28.6	$(1 \frac{1}{8})$	7.9	$(\frac{5}{16})$	45.2	$(1 \frac{25}{32})$
31.8	$(1 \frac{1}{4})$	7.9	$(\frac{5}{16})$	48.4	$(1 \frac{29}{32})$
34.9	$(1 \frac{3}{8})$	7.9	$(\frac{5}{16})$	51.6	$(2 \frac{1}{32})$
38.1	$(1 \frac{1}{2})$	9.5	$(\frac{3}{8})$	57.9	$(2 \frac{9}{32})$
41.3	$(1 \frac{5}{8})$	9.5	$(\frac{3}{8})$	61.1	$(2 \frac{13}{32})$
44.4	$(1 \frac{3}{4})$	9.5	$(\frac{3}{8})$	64.3	$(2 \frac{17}{32})$
47.6	$(1 \frac{7}{8})$	9.5	$(\frac{3}{8})$	67.5	$(2 \frac{21}{32})$
50.8	(2)	11.1	$(\frac{7}{16})$	73.8	$(2 \frac{29}{32})$
54.0	$(2 \frac{1}{8})$	11.1	$(\frac{7}{16})$	77.0	$(3 \frac{1}{32})$
57.2	$(2 \frac{1}{4})$	12.7	$(\frac{1}{2})$	83.3	$(3 \frac{9}{32})$
60.3	$(2 \frac{3}{8})$	12.7	$(\frac{1}{2})$	86.5	$(3 \frac{13}{32})$
63.5	$(2 \frac{1}{2})$	12.7	$(\frac{1}{2})$	89.7	$(3 \frac{17}{32})$
69.8	$(2 \frac{3}{4})$	12.7	$(\frac{1}{2})$	96.0	$(3 \frac{25}{32})$
73.0	$(2 \frac{7}{8})$	14.3	$(\frac{9}{16})$	102.4	$(4 \frac{1}{32})$
76.2	(3)	14.3	$(\frac{9}{16})$	105.6	$(4 \frac{5}{32})$
82.6	$(3 \frac{1}{4})$	19.0	$(\frac{3}{4})$	121.4	$(4 \frac{25}{32})$
88.9	$(3 \frac{1}{2})$	19.0	$(\frac{3}{4})$	127.8	$(5 \frac{1}{32})$
95.2	$(3 \frac{3}{4})$	19.0	$(\frac{3}{4})$	134.1	$(5 \frac{9}{32})$
101.6	(4)	19.0	$(\frac{3}{4})$	140.5	$(5 \frac{17}{32})$
108.0	$(4 \frac{1}{4})$	19.0	$(\frac{3}{4})$	146.8	$(5 \frac{25}{32})$
127.0	(5)	25.4	(1)	178.6	$(7 \frac{1}{32})$

^a For intermediate sizes of stem one of the standard packing widths listed shall be used.

17 Bypass

17.1 A bypass shall not be provided unless specified in the order.

17.2 Any bypass supplied shall be external to the main valve and be of the following size:

Nominal size	Bypass size
mm	in
50 to 100	$\frac{1}{2}$
150 to 200	$\frac{3}{4}$
250 to 300	1
350 and larger	$1\frac{1}{2}$

18 Soft seal rings

18.1 Soft seal rings may be fitted in either the body seats or in the wedge seats as specified by the purchaser. The rings shall be designed to compress down to the level of the metal seats to give a tight shut-off on both sides of the wedge and thus provide a "double block and bleed" facility. They shall also give a tight metal-to-metal seal through the valve if the soft seals are damaged or removed.

18.2 The seal rings shall be designed to withstand a minimum of 2 000 cycles of operation in dry atmospheric conditions and there shall then be no evidence of damage or cold flow, as revealed by spreading over the metal seats. The valves shall then meet the hydrostatic and air tests specified in BS 5146.

A $\frac{1}{2}$ in tapping fitted with a plug shall be provided in the bonnet for testing the double block and bleed facility. This shall be located in position H (see Figure 3) unless specified otherwise by the purchaser. The type of thread shall be stated if other than API Std 5B.

18.3 The effective operating temperature range of soft seal valves will be limited by the service temperature of the seal material.

Section 3. Materials

19 Shell

The body and bonnet shall be of the material specified in the order, the selection being made from those listed in BS 1560-2. All pressure containing parts involved in welding operations shall have the carbon content restricted as follows:

- 0.25 % maximum for carbon or carbon/molybdenum steels;
- 0.15 % maximum for 5 % Cr $\frac{1}{2}$ % Mo steel.

20 Body seat rings

A body seat ring made of a material different from its seating surface shall be of a material not inferior to that of the shell.

21 Bonnet gasket

Bonnet flange gaskets shall be metallic spiral wound as specified in BS 3381, or steel or soft iron, except that, for Class 150 valves only, compressed asbestos fibre complying with the requirements of BS 1832 is an acceptable alternative. They shall be suitable for the pressure/temperature rating of the valve. Any metallic part of the gasket shall have at least the same corrosion resistance as the shell.

NOTE Free chlorides in compressed asbestos fibre materials when used with low alloy or austenitic stainless steels may cause stress corrosion cracking in the flange and the use of alternative gasket materials should be considered.

22 Wedge

A wedge fitted with separate facing rings, or on which seating surfaces are deposited by welding, shall be of a material equal to that of the shell.

23 Yoke

A yoke separate from the bonnet shall be of carbon steel or of the same material as that of the shell.

24 Handwheel or chainwheel

The handwheel or chainwheel shall be of steel, malleable iron or nodular iron.

25 Handwheel or chainwheel nut

The handwheel or chainwheel nut shall be of copper alloy, steel, malleable iron or nodular iron. If of carbon steel it shall be suitably protected against corrosion.

26 Yoke sleeve

The yoke sleeve shall be of non-rusting metal having a suitable bearing quality and a melting point above 955 °C.

27 Yoke sleeve retaining nut

The yoke sleeve retaining nut shall be of a material having a melting point above 955 °C. Grey cast iron shall not be used. If malleable cast iron is used it shall comply with the requirements of BS 6681 for grade B 32-10 or grade B 35-12. If spheroidal graphite cast iron is used it shall comply with the requirements of BS 2789 grades 350/22, 400/18 or 420/12.

28 Gland

A one piece gland or any gland flange shall be of steel. The bushing of a one piece bushed gland or the gland proper of a two piece gland shall be made of a material having a minimum melting point above 955 °C.

29 Trim

29.1 Trim comprises the following:

- a) stem;
- b) body seat surfaces;
- c) wedge seat surfaces;
- d) back seat bushing.

29.2 The trim materials shall be selected from those listed in Table 2 and specified in the order by quoting the relevant nominal trim symbol.

29.3 If a combination trim, e.g. CR 13 and Cu-Ni, is specified, either material may be used for the body seat surface. The other material of the combination shall be used for the wedge seat surface.

29.4 Stems shall be of wrought material.

29.5 The temperature limitations of certain trim materials may restrict the pressure/temperature ratings of the valve to which they are fitted.

30 Lantern ring

A lantern ring, when supplied, shall be of a material not inferior to that of the shell.

31 Stem packing

The packing shall be of braided asbestos containing a suitable corrosion inhibitor. Unless the order specifies other packing or a higher packing design temperature, it shall be suitable for use with steam or petroleum fluid at a minimum packing design temperature of 400 °C.

32 Bolting

32.1 Bonnet bolts shall comply with the requirements of BS 1506-630-860 (BS 4882:1973, section 3, grade B7) and nuts shall comply with the requirements of BS 1506-162 (BS 4882:1973, section 3, grade 2H) unless other bolting material is specified in the order.

32.2 Material for gland and yoke bolting shall be carbon steel of at least 392 N/mm² ¹⁾ tensile strength unless other bolting material is specified in the order. Free cutting steels shall not be used.

¹⁾ 1 N/mm² = 1 MPa.

33 Plugs

Material for shell plugs shall be not inferior to that of the shell.

34 Nameplate

34.1 For valves of nominal size 150 mm (6 in) and larger the nameplate shall be of 18-8 Cr-Ni steel or nickel alloy attached to the valve by pins of similar material or by welding.

34.2 For smaller valves, the nameplate material and attachment shall be of corrosion resistant material in accordance with the manufacturer's standard. Brass and aluminium are acceptable.

35 Soft seals

Soft seals shall be of the manufacturer's standard material for the duties specified. Any retaining ring in the wedge shall be of the same material as the stem but any fixing screws shall be of 18-8 Cr-Ni steel.

36 Special applications

When valves are specified for highly corrosive services or environment, or for low temperature service, the material specification for all parts shall be subject to agreement between the purchaser and the manufacturer.

Section 4. Marking

37 Required markings

Every valve in accordance with this standard shall be clearly marked as follows.

- a) Body and bonnet markings shall be integral.
- b) Every valve shall have a nameplate securely fastened to it.

38 Body and nameplate markings

Body and nameplate markings shall be as follows.

- a) Nominal size designation. The numeral(s) denoting the nominal size prefixed by the letters DN, e.g. DN 100 (see clause 6).
- b) Class rating. The numerals denoting the class rating (see clause 4).
- c) Body material identification. Standard symbol from BS 1560-2:1970, Table 25.
- d) Manufacturer's name or trade mark.
- e) The number of this British Standard, i.e. BS 1414.

Table 2 — Trim materials, hardness and acceptable specifications

1	2	3	4	5	6	7	8	9	10	11	12	13
Nominal trim symbol	Material type			Minimum Brinell hardness ^a			Acceptable material specifications					
	Seat surfaces	Stem	Back seat bushing ^c	Seat surfaces	Stem	Back seat bushing	Cast ^b		Forged		Bar	
							BS	ASTM	BS	ASTM	BS	ASTM
CR 13	13 Cr	13 Cr	13 Cr	^d	200	250	1504-420C29	A487-CA15 A487-CA6NM	1503-410S21	A182-F6	1506-410S21	A276-410
18-8 Ti	18-8 Cr-Ni-Ti	18-8 Cr-Ni-Ti	18-8 Cr-Ni-Ti	Manufacturer's standard			1504-347C17	—	1503-321S31 1503-321S51	A182-F321	1506-321S31	A276-321
18-8 Nb	18-8 Cr-Ni-Nb	18-8 Cr-Ni-Nb	18-8 Cr-Ni-Nb	Manufacturer's standard			1504-347C17	A351-CF8C	1503-347S31 1503-347S51	A182-F347	1506-347S31	A276-347
18-10-2	18-10-2 Cr-Ni-Mo	18-10-2 Cr-Ni-Mo	18-10-2 Cr-Ni-Mo	Manufacturer's standard			1504-316C16	A351-CF8M	1503-316S31 1503-316S33	A182-F316	1506-316S31 1506-316S33	A276-316
18-12-3	18-12-3 Cr-Ni-Mo	18-12-3 Cr-Ni-Mo	18-12-3 Cr-Ni-Mo	Manufacturer's standard			1504-317C16	—	1503-316S33	—	—	A276-317
25-20	25-20 Cr-Ni	25-20 Cr-Ni	25-20 Cr-Ni	Manufacturer's standard			—	—	—	A182-F310	—	—
HF	66-26-5 Co-Cr-W	—	—	350 ^e	—	—	—	—	—	—	—	—
	—	13 Cr	13 Cr	—	200	250	1504-420C29	A487-CA15	1503-410S21	A182-F6	1506-410S21	A276-410
CR 13 and Cu-Ni	13 Cr	13 Cr	13 Cr	250 ^f	200	250	1504-420C29	A487-CA15	1503-410S21	A182-F6	1506-410S21	A276-410
	Cu-Ni	—	—	175 ^f	—	—	Manufacturer's standard with 30 % nickel min.					
CR 13 and HF	13 Cr	13 Cr	13 Cr	300 ^f	200	250	1504-420C29	A487-CA15	1503-410S21	A182-F6	1506-410S21	A276-410
	66-26-5 Co-Cr-W	—	—	350 ^f	—	—	—	—	—	—	—	—
Ni-Cu	Ni-Cu Alloy	Ni-Cu Alloy	Ni-Cu Alloy	—	—	—	3071 NA1	—	—	—	3076 NA13	—
AB	Aluminium bronze	Aluminium bronze	Aluminium bronze	Manufacturer's standard			1400-AB1, 1400-AB2	B148-952A, B148-955D	2872-CA104	B124-642 B124-630	2874-CA107 2874-CA104	B150-642 B150-630
B	Bronze	—	Bronze	Manufacturer's standard			1400-G1, 1400-LG2	B584-905 B584-836	—	—	—	—
	—	Manganese bronze	Manganese bronze	Manufacturer's standard			1400-HTB1	B584-864 B584-865	2872-CZ114	B138-675	2874-CZ114	B138-675

^a See BS 240-1.

^b Castings not applicable to stem materials; see 29.4.

^c For austenitic trims the backseat may alternatively be a weld deposit of the same nominal material composition as the trim or a welded-on hard facing. For hard faced (HF) trim the back seat may alternatively be a welded-on hard facing.

^d Body and wedge seat surfaces 250 HB min., with 50 HB min. differential between body and wedge seat surfaces.

^e Differential hardness between body and wedge seat surfaces is not required.

^f Differential hardness between body and wedge seat surfaces shall be the Manufacturer's standard.

39 Body and bonnet markings

39.1 Melt identification. Melt identification is required on all pressure containing steel castings.

39.2 Ring joint number. Pipe end flanges and body/bonnet flanges grooved for ring joints and the rings to be used with them shall be marked with the corresponding ring number (e.g. R 25). This identification shall be placed on the rim of both pipe end flanges or the bonnet end flange of the body as applicable and on the outside periphery of the ring. For ring numbers see Appendix A. In the case of non-standard ring joints for body/bonnet flanges the flange and ring shall be marked R SpL.

40 Nameplate markings

40.1 Pressure/temperature restrictions. Any pressure or temperature restrictions within the appropriate ratings given in BS 1560-2 that may be imposed by the manufacturer due to limitations on materials or design shall be shown on the nameplate.

Such special limiting pressure/temperature ratings shall also comply with the appropriate BS 1560-2 rating table.

40.2 Valve trim identification. Trim materials shall be indicated in the following order, using the appropriate symbol from Table 2,

- 1) STEM 2) WEDGE 3) SEAT

as in the example below:

STEM	CR 13		CR 13
WEDGE HF	or	CR 13 HF	CR 13 or HF
SEAT	CR 13		CR 13

40.3 Identification number. The manufacturer's figure or number identifying the valve in all respects shall be shown. The same figure or number shall therefore only be used for valves which are identical in design, detail, dimensions and material and which have interchangeable parts.

41 Additional markings

Additional markings may be used at the option of the manufacturer provided they do not conflict with any of the markings specified in this standard.

42 Omission of markings

42.1 Where the size or shape of the valve body precludes the inclusion of all the required markings, they may be omitted from the body only as found necessary subject to the approval of the purchaser. The sequence of omission shall be as follows.

- 1) Nominal size
- 2) Manufacturer's name or trade mark
- 3) Class rating.

42.2 The number of this British Standard may be omitted from the body or the nameplate, but not from both, at the manufacturer's option.

Section 5. Testing

43 Production pressure testing

All valves shall be pressure tested by the manufacturer before despatch in accordance with BS 6755-1 as follows:

- a) hydrostatic shell and backseat tests;
- b) hydrostatic seat test (see note);
- c) pneumatic seat test (see note).

The test durations shall be as given in Table 2a.

NOTE Attention is drawn to note of D.8.3.2 of BS 6755-1:1986 regarding the sequence of operations when the seat test procedure is carried out. Valves tested to BS 1414 should have the sequence of items b) and c) in D.8.3.2 of BS 6755-1:1986 reversed. Seat test leakage rate A should apply. For the backseat test there should be no visual leakage for the duration of the test time.

Table 2a — Test durations

Nominal valve size	Minimum test duration		
	Shell test	Backseat test	Seat test
Up to and including DN 50	s	s	s
DN 65 up to and including DN 150	15	15	15
DN 200 up to and including DN 300	60	15	60
DN 350 and larger	120	15	120

Section 6. Shipping

44 Preliminary

After inspection and before preparation for despatch all valves shall be thoroughly cleaned and dried.

45 Preparation for despatch

45.1 Coating. Coating of valves shall be as follows.

- a) Unmachined external surfaces of the valves shall be painted with aluminium finish paint, except for austenitic steel valves which shall not be painted.
- b) Machined or threaded surfaces shall be coated with an easily removable rust protective (see BS 1133-6) except that this shall not be required for austenitic steel components.

45.2 End protection. After complying with the requirements of 45.1, body end ports, flange faces and butt-welding ends shall be covered with suitable close fitting protectors to protect the machined ends and prevent ingress of dirt and moisture.

45.3 Stem packing. The stem packing shall be fitted before shipping.

45.4 Wedge. The wedge shall be closed before shipping except in the case of soft seal valves where the wedge shall be backed off to relieve the pressure on the seals.

46 Packaging

Valves shall be so packaged as to minimize the possibility of damage during storage or transit. Where tropical or special packaging is necessary, the purchaser shall specify his requirements.

Appendix A Particular dimensions for each class of valve

Table 3 — Dimensions of Class 150 valves

1		2	3	4	5	6
Nominal size		Inside diameter of flanged valves (min) ^a	Body and bonnet thickness (min)	Ring number for ring joints	Stem diameter (min.)	
mm	(in)	mm	mm		mm	
25	(1)	25	6.4	R15	15.9	
32 ^b	(1¼) ^b	32	6.4	R17	15.9	
40	(1½)	38	6.4	R19	17.5	
50	(2)	51	8.7	R22	19.0	
65 ^b	(2½) ^b	64	9.5	R25	19.0	
80	(3)	76	10.3	R29	22.2	
100	(4)	102	11.1	R36	25.4	
150	(6)	152	11.9	R43	28.6	
200	(8)	203	12.7	R48	31.8	
250	(10)	254	14.3	R52	34.9	
300	(12)	305	15.9	R56	38.1	
350	(14)	337	16.7	R59	41.3	
400	(16)	387	17.5	R64	44.4	
450	(18)	438	18.2	R68	47.6	
500	(20)	489	19.0	R72	50.8	
600	(24)	591	20.6	R76	57.2	
650	(26)	635	21.4	—	60.3	
700	(28)	686	22.2	—	63.5	
750	(30)	737	23.0	—	63.5	
900	(36)	876	25.4	—	69.8	
1 050	(42)	1 020	28.6	—	82.6	

^a For details of welding ends including inside diameters see Figure 2.
^b These sizes have been retained for the purpose of replacing existing valves. Their use for new construction in piping systems using BS 1560-2 flanges should be avoided.

Table 4 — Dimensions of Class 300 valves

1	2	3	4	5	6
Nominal size		Inside diameter of flanged valves (min.) ^a	Body and bonnet thickness (min.)	Ring number for ring joints	Stem diameter (min.)
mm	(in)	mm	mm		mm
25	(1)	25	6.4	R16	15.9
32 ^b	(1 $\frac{1}{4}$) ^b	32	6.4	R18	15.9
40	(1 $\frac{1}{2}$)	38	7.9	R20	19.0
50	(2)	51	9.5	R23	19.0
65 ^b	(2 $\frac{1}{2}$) ^b	64	11.1	R26	19.0
80	(3)	76	11.9	R31 ^c	22.2
100	(4)	102	12.7	R37	25.4
150	(6)	152	15.9	R45	31.8
200	(8)	203	17.5	R49	34.9
250	(10)	254	19.0	R53	38.1
300	(12)	305	20.6	R57	41.3
350	(14)	337	22.2	R61	44.4
400	(16)	387	23.8	R65	47.6
450	(18)	432	25.4	R69	50.8
500	(20)	483	27.0	R73	54.0
600	(24)	584	30.2	R77	63.5
650	(26)	635	31.8	—	69.8
700	(28)	686	33.3	—	76.2
750	(30)	737	34.9	—	82.6
900	(36)	876	41.3	—	88.9
1 050	(42)	1 020	44.4	—	101.6

^a For details of welding ends including inside diameters see Figure 2.

^b These sizes have been retained for the purpose of replacing existing valves. Their use for new construction in piping systems using BS 1560-2 flanges should be avoided.

^c For valves of 80 mm (3 in) nominal size, if intended to be used in conjunction with lapped flanges, the ring number shall be R30.

Table 5 — Dimensions of Class 400 valves

1	2	3	4	5	6
Nominal size		Inside diameter of flanged valves (min.) ^a	Body and bonnet thickness (min.)	Ring number for ring joints	Stem diameter (min.)
mm	(in)	mm	mm		mm
100	(4)	102	12.7	R37	28.6
150	(6)	152	16.7	R45	34.9
200	(8)	203	19.0	R49	38.1
250	(10)	254	21.4	R53	44.4
300	(12)	305	23.8	R57	47.6
350	(14)	333	27.0	R61	47.6
400	(16)	381	28.6	R65	50.8
450	(18)	432	30.2	R69	57.2
500	(20)	479	33.3	R73	63.5
600	(24)	575	36.5	R77	69.8

^a For details of welding ends including inside diameters see Figure 2.

Table 6 — Dimensions of Class 600 valves

1	2	3	4	5	6
Nominal size		Inside diameter of flanged valves (min.) ^a	Body and bonnet thickness (min.)	Ring number for ring joints	Stem diameter (min.)
mm	(in)	mm	mm		mm
25	(1)	25	7.9	R16	15.9
32 ^b	(1¼) ^b	32	8.6	R18	15.9
40	(1½)	38	9.3	R20	19.0
50	(2)	51	11.1	R23	19.0
65 ^b	(2½) ^b	64	11.9	R26	22.2
80	(3)	76	12.7	R31 ^c	25.4
100	(4)	102	15.9	R37	28.6
150	(6)	152	19.0	R45	38.1
200	(8)	200	25.4	R49	41.3
250	(10)	248	28.6	R53	47.6
300	(12)	298	31.8	R57	50.8
350	(14)	327	34.9	R61	57.2
400	(16)	375	38.1	R65	60.3
450	(18)	419	41.3	R69	63.5
500	(20)	464	44.4	R73	69.8
600	(24)	559	50.8	R77	76.2

^a For details of welding ends including inside diameters see Figure 2.

^b These sizes have been retained only for the purpose of replacing existing valves. Their use for new construction in piping systems using BS 1560-2 flanges should be avoided.

^c For valves of 80 mm (3 in) nominal size, if intended to be used in conjunction with lapped flanges, the ring number shall be R30.

Table 7 — Dimensions of Class 900 valves

1	2	3	4	5	6
Nominal size		Inside diameter of flanged valves (min.) ^a	Body and bonnet thickness (min.)	Ring number for ring joints	Stem diameter (min.)
mm	(in)	mm	mm		mm
80	(3)	73	19.0	R31	28.6
100	(4)	98	21.4	R37	31.8
150	(6)	146	26.2	R45	41.3
200	(8)	190	31.8	R49	47.6
250	(10)	238	36.5	R53	54.0
300	(12)	283	42.1	R57	57.2
350	(14)	311	46.0	R62	60.3
400	(16)	356	52.4	R66	63.5
450	(18)	400	57.2	R70	76.2
500	(20)	444	63.5	R74	82.6
600	(24)	533	73.0	R78	101.6

^a For details of welding ends including inside diameters see Figure 2.

Table 8 — Dimensions of Class 1 500 valves

1	2	3	4	5	6
Nominal size		Inside diameter of flanged valves (min.) ^a	Body and bonnet thickness (min.)	Ring number for ring joints	Stem diameter (min.)
mm	(in)	mm	mm		mm
25	(1)	22	12.7	R16	19.0
32 ^b	(1¼) ^b	29	14.2	R18	19.0
40	(1½)	35	15.0	R20	22.2
50	(2)	48	19.0	R24	25.4
65 ^b	(2½) ^b	57	22.2	R27	28.6
80	(3)	70	23.8	R35	31.8
100	(4)	92	28.6	R39	34.9
150	(6)	137	38.1	R46	44.4
200	(8)	178	47.6	R50	54.0
250	(10)	222	57.2	R54	63.5
300	(12)	264	66.7	R58	69.8
350	(14)	289	69.8	R63	76.2
400	(16)	330	79.4	R67	82.6
450	(18)	371	88.9	R71	95.2
500	(20)	416	98.4	R75	108.0
600	(24)	498	114.3	R79	127.0

^a For details of welding ends including inside diameters see Figure 2.

^b These sizes have been retained only for the purpose of replacing existing valves. Their use for new construction in piping systems using BS 1560-2 flanges should be avoided.

Table 9 — Dimensions of Class 2 500 valves

1	2	3	4	5	6
Nominal size		Inside diameter of flanged valves (min.) ^a	Body and bonnet thickness (min.)	Ring number for ring joints	Stem diameter (min.)
mm	(in)	mm	mm		mm
25	(1)	19	15.1	R18	19.0
32 ^b	(1¼) ^b	25	17.5	R21	19.0
40	(1½)	29	19.0	R23	22.2
50	(2)	38	22.2	R26	25.4
65 ^b	(2½) ^b	48	25.4	R28	28.6
80	(3)	57	30.2	R32	31.8
100	(4)	73	35.7	R38	34.9
150	(6)	111	48.4	R47	47.6
200	(8)	146	61.9	R51	60.3
250	(10)	184	67.5	R55	73.0
300	(12)	219	86.5	R60	82.6

^a For details of welding ends including inside diameters see Figure 2.

^b These sizes have been retained only for the purpose of replacing existing valves. Their use for new construction in piping systems using BS 1560-2 flanges should be avoided.

Appendix B Application to piping systems with BS 4504 flanges

B.1 General

Valves in accordance with this British Standard, BS 1414, may be supplied for use in piping systems with BS 4504 flanges when specified by the purchaser. When this is the case all the requirements of this British Standard, BS 1414, apply, with the qualifications specified in B.2 to B.7.

B.2 Pressure/temperature ratings

The pressure/temperature ratings of valves with BS 4504 flanges shall be in accordance with BS 4504:1969, Table A.1. Pressure/temperature ratings for valves in materials other than those listed in BS 4504:1969, Table A.1 shall be agreed between the purchaser and the manufacturer.

B.3 Nominal pressure and class ratings and nominal size range

Valves in accordance with this appendix with flanges of the nominal pressure ratings given in column 1 of Table 10 shall have the same face-to-face dimensions as valves with BS 1560-2 flanges of the corresponding class ratings in column 2. Column 3 gives the applicable nominal size range.

Table 10 — Nominal pressure and class ratings and nominal size range

1	2	3	4
Rating		Nominal size range	
PN	Class		
		mm	(in)
10	150	50 to 600	(2 to 24)
16	150	50 to 600	(2 to 24)
25	300	25 to 600	(1 to 24)
40	300	25 to 600	(1 to 24)
64	600	25 to 600	(1 to 24)
100	600	25 to 600	(1 to 24)
160	900	25 to 300	(1 to 12)
250	1 500	25 to 300	(1 to 12)
320	2 500	25 to 250	(1 to 10)
400	2 500	25 to 200	(1 to 8)

B.4 Body end flanges

B.4.1 Dimensions. Body end flange dimensions shall comply with the requirements of BS 4504 except that flange thicknesses may be the appropriate values from BS 1560-2. Flange thicknesses shall be not less than those specified in BS 4504. When flange thicknesses comply with those specified in BS 4504, the neck dimensions shall also comply with the requirements of BS 4504.

B.4.2 Spot-facing or back-facing. The requirements of BS 1560-2 for spot-facing or back-facing shall be complied with.

B.4.3 Finish of joint surface. The joint surface finish shall comply with the requirements of BS 4504.

B.5 Text deleted.

B.6 Marking

When supplied for use in piping systems with BS 4504 flanges valves shall be permanently marked with the appropriate nominal pressure rating (i.e. PN.). This marking may replace or supplement the requirements of clause 38 b) and shall appear on all BS 4504 flanges used.

B.7 Information to be supplied by the purchaser

The information to be supplied by the purchaser shall be as listed in clause 7 of this standard except that a) shall be replaced by the following.

- State that valves are to comply with the requirements of this appendix and state nominal pressure rating and nominal size.

Publications referred to

This standard makes reference to the following British Standards:

BS 240, *Method for Brinell hardness test.*

BS 240-1, *Testing of metals.*

BS 1133, *Packaging code.*

BS 1133-6, *Temporary protection of metal surfaces against corrosion (during transport and storage).*

BS 1400, *Specification for copper alloy ingots and copper alloy and high conductivity copper castings.*

BS 1503, *Specification for steel forgings (including semi-finished forged products) for pressure purposes.*

BS 1504, *Specification for steel castings for pressure purposes.*

BS 1506, *Specification for carbon, low alloy and stainless steel bars and billets for bolting material to be used in pressure retaining applications.*

BS 1560, *Steel pipe flanges and flanged fittings (nominal sizes $\frac{1}{2}$ in to 24 in) for the petroleum industry.*

BS 1560-2, *Metric dimensions.*

BS 1600, *Dimensions of steel pipe for the petroleum industry.*

BS 1600-2, *Metric units.*

BS 1768, *Unified precision hexagon bolts, screws and nuts (UNC and UNF threads). Normal series.*

BS 1769, *Unified black hexagon bolts, screws and nuts (UNC and UNF threads). Heavy series.*

BS 1832, *Oil resistant compressed asbestos fibre jointing.*

BS 2080, *Face-to-face, centre-to-face, end-to-end and centre-to-end dimensions of flanged and butt-welding end steel valves for the petroleum, petrochemical and allied industries.*

BS 2693, *Screwed studs.*

BS 2693-1, *General purpose studs.*

BS 2789, *Specification for spheroidal graphite or nodular graphite cast iron.*

BS 2872, *Copper and copper alloys. Forging stock and forgings.*

BS 2874, *Copper and copper alloys. Rods and sections (other than forging stock).*

BS 3071, *Nickel-copper alloy castings.*

BS 3076, *Nickel and nickel alloys. Rods.*

BS 3293, *Carbon steel pipe flanges (over 24 in nominal size) for the petroleum industry.*

BS 3351, *Piping systems for petroleum refineries and petrochemical plants.*

BS 3381, *Metallic spiral wound gaskets for the petroleum and petrochemical industry.*

BS 3600, *Dimensions and masses per unit length of welded and seamless steel pipes and tubes for pressure purposes.*

BS 3692, *ISO metric precision hexagon bolts, screws and nuts.*

BS 3799, *Forged steel pipe fittings, screwed and socket-welding for the petroleum industry.*

BS 4190, *ISO metric black hexagon bolts, screws and nuts.*

BS 4504, *Flanges and bolting for pipes, valves and fittings. Metric series.*

BS 4882, *Bolting for flanges and pressure containing purposes.*

BS 6681, *Specification for malleable cast iron.*

BS 6755, *Testing of valves.*

BS 6755-1, *Specification for production pressure testing requirements.*

BS, *Flange attachment dimensions of actuators to general purpose valves²⁾.*

²⁾ In course of preparation.

BSI — British Standards Institution

BSI is the independent national body responsible for preparing British Standards. It presents the UK view on standards in Europe and at the international level. It is incorporated by Royal Charter.

Revisions

British Standards are updated by amendment or revision. Users of British Standards should make sure that they possess the latest amendments or editions.

It is the constant aim of BSI to improve the quality of our products and services. We would be grateful if anyone finding an inaccuracy or ambiguity while using this British Standard would inform the Secretary of the technical committee responsible, the identity of which can be found on the inside front cover. Tel: 020 8996 9000. Fax: 020 8996 7400.

BSI offers members an individual updating service called PLUS which ensures that subscribers automatically receive the latest editions of standards.

Buying standards

Orders for all BSI, international and foreign standards publications should be addressed to Customer Services. Tel: 020 8996 9001. Fax: 020 8996 7001.

In response to orders for international standards, it is BSI policy to supply the BSI implementation of those that have been published as British Standards, unless otherwise requested.

Information on standards

BSI provides a wide range of information on national, European and international standards through its Library and its Technical Help to Exporters Service. Various BSI electronic information services are also available which give details on all its products and services. Contact the Information Centre. Tel: 020 8996 7111. Fax: 020 8996 7048.

Subscribing members of BSI are kept up to date with standards developments and receive substantial discounts on the purchase price of standards. For details of these and other benefits contact Membership Administration. Tel: 020 8996 7002. Fax: 020 8996 7001.

Copyright

Copyright subsists in all BSI publications. BSI also holds the copyright, in the UK, of the publications of the international standardization bodies. Except as permitted under the Copyright, Designs and Patents Act 1988 no extract may be reproduced, stored in a retrieval system or transmitted in any form or by any means – electronic, photocopying, recording or otherwise – without prior written permission from BSI.

This does not preclude the free use, in the course of implementing the standard, of necessary details such as symbols, and size, type or grade designations. If these details are to be used for any other purpose than implementation then the prior written permission of BSI must be obtained.

If permission is granted, the terms may include royalty payments or a licensing agreement. Details and advice can be obtained from the Copyright Manager. Tel: 020 8996 7070.